



Fire & Life Safety Requirements For Fire Department Access and Water Supplies

This brochure is being provided as a resource only.

The items listed inside are the requirements most generally cited on plans for approval.

If these items are included on the plans, the likelihood of a timely approval on the initial review is greatly increased. If questions arise with regard to any of the provisions, please call.

Fire Marshal's Office:

2860 Southwest Dr.
Sedona, AZ 86336
(928) 204-8926

- 1) FIRE APPARATUS ACCESS ROAD DISTANCE FROM BUILDING AND TURNAROUNDS:** Access roads shall be within 150 feet of all portions of the exterior wall of the first story of the building as measured by an approved route around the exterior of the building. An approved turnaround is required if the remaining distance to an approved intersecting roadway, as measured along the fire apparatus access road, is greater than 150 feet. (SFC Sec. 503.1.1)
- 2) ACCESS ROADS ADJACENT TO BUILDINGS:** Access roadways shall not be closer than 20 feet to a structure unless topographical restrictions dictate the location. (SFC Sec. 503.1.1)
- 3) FIRE APPARATUS ACCESS ROAD WIDTH AND VERTICAL CLEARANCE:** Fire apparatus access roads shall have an unobstructed width of not less than 20 feet (14 feet with 12 foot minimum driving surface for one or two dwelling units and out buildings), and an unobstructed vertical clearance of not less than 13 feet 6 inches. (SFC Sec. 503.2.1)
- 4) AERIAL APPARATUS ROAD WIDTHS:** Buildings more than 30 feet in height shall have fire apparatus access roads constructed for use by aerial apparatus with an unobstructed driving surface width of not less than 26 feet. (SFC Appendix D, Sec. D105)
- 5) SURFACE AND LOAD CAPACITIES:** Fire apparatus access roads shall be of an all-weather surface that is easily distinguishable from the surrounding area and is capable of supporting not less than 12,500 pounds point load (wheel load) and 75,000 pounds live load (gross vehicle weight). You may need to provide documentation from a registered engineer that the design will be capable of supporting such loading. Documentation from a registered engineer that the finished construction is in accordance with the approved plans or the requirements of the Fire Code may be requested. (SFC Sec. 503.2.3 and D102.1)
- 6) FIRE APPARATUS ACCESS ROAD GATES:** Gates securing the fire apparatus access roads shall comply with all of the following criteria:
 - The minimum gate width shall be 20 feet.
 - Gates shall be of the swinging or sliding type.
 - Construction of gates shall be of materials that allow manual operation by one person.
 - Gate components shall be maintained in an operative condition at all times and replaced or repaired when defective.
 - Electric gates shall be equipped with a means of opening the gate by fire department personnel for emergency access. Emergency opening devices shall be from the Knox Box Rapid Entry system and shall be approved by the fire code official.
 - Manual opening gates shall not be locked with a padlock or chain and padlock unless they are Sedona Fire District padlocks.
 - Locking device specifications shall be submitted for approval by the fire code official.
- 7) BRIDGES AND ELEVATED SURFACES.** Where a bridge or an elevated surface is part of a fire apparatus access road, the bridge shall be constructed and maintained in accordance with AASHTO *Standard Specification for Highway Bridges*. Bridges and elevated surfaces shall be designed for a live load sufficient to carry the imposed loads of fire apparatus, (75,000 lbs). Vehicle load limits shall be posted at both entrances to bridges when required by the fire code official. Where elevated surfaces designed for emergency vehicle use are adjacent to surfaces which are not designed for such use, approved barriers, approved signs or both shall be installed and maintained when required by the fire code official. (SFC Sec. 503.2.6)

8) GRADE: Private fire apparatus access roadway grades shall not exceed an average grade of 10 percent with a maximum grade of 15 percent for lengths of no more than 200 feet. Intersections and turnarounds shall be level (maximum 5%) with the exception of crowning for water run-off. Public streets shall have a maximum grade of 15%. (SFC Sec. 503.2.7 and D103.2)

Note: A 12% grade may be exceeded when an automatic fire sprinkler system is installed, but in no case shall the grade exceed 20 percent.

9) TURNING RADIUS: The inside turning radius and outside turning radius shall be not less than 28 feet and 48 feet respectively, measured from the same center point. (SFC Sec. 503.2.4) – (See diagrams attached)

10) DRAINAGE: When subject to run-off damage, access roads shall be provided with approved drainage. (SFC Sec D103.3.2)

11) DEAD END ROADS: Dead end fire apparatus access roads in excess of 150 feet in length shall be provided with approved width and turnaround provisions. (SFC Sec. 503.2.5 and D103.4) - (see diagrams on back)

12) ADDITIONAL ACCESS ROADS: Developments of more than 30 dwelling units, buildings exceeding three stories in height, buildings exceeding 62,000 square feet, multi-family developments with more than 100 dwelling units, vehicle congestion, adverse terrain conditions or other factors as determined by the Chief of the fire department shall provide not less than two approved means of access to the city/county roadway or access easement. Exceptions may be allowed for approved automatic sprinkler system. (SFC Sec. 503.1.2 and Appendix D)

13) NO PARKING SIGNS: Where fire apparatus roadways are not of sufficient width to accommodate parked vehicles and 20 feet of unobstructed driving surface, "No Parking" signs shall be installed on one or both sides of the roadway and in turnarounds as needed. (SFC Sec. 503.4 and D103.6)

A. Fire apparatus access roads 20 to 26 feet wide shall be posted on both sides as a fire lane. (SFC Sec. D103.6.1)

B. Fire apparatus access roads more than 26 feet wide to 32 feet wide shall be posted on one side of the road as a fire lane. (SFC Sec. D103.6.2)

C. Signs shall read "NO PARKING - FIRE LANE" and shall be installed with a clear space above grade level of 7 feet. Signs shall be 12 inches wide by 18 inches high and shall have red letters and border on a white background. (SFC Sec. D103.6) – (See diagram attached)

14) PAINTED CURBS: Where required, fire apparatus access roadway curbs shall be painted red and marked "NO PARKING FIRE LANE" at each 25 feet. Lettering shall have a stroke of not less than one inch wide by six inches high. Lettering shall be white on red background. (SFC Sec. 503.4)

15) ACCESS ROAD SIGNAGE: Access roads, private or public, shall be marked with approved signs in accordance to City or County standards and comply with Arizona Department of Transportation guidelines. (SFC Sec. 503.3)

16) WATER SUPPLY: An approved water supply capable of supplying the required fire flow for fire protection shall be provided to premises upon which facilities, buildings or portions of buildings are hereafter constructed or moved into or within the jurisdiction. (SFC Sec. 508.1)

17) REQUIRED FIRE FLOW: The required fire flow for the building shall not exceed 3,000 gallons per minute (GPM) or the available GPM in the water delivery system at 20 psi, whichever is less. A worksheet for calculating the required fire flow is available from the Fire Marshal's Office. (SFC Sec. 508.3)

18) RURAL BUILDINGS - REQUIRED WATER SUPPLY: Required fire flow for rural buildings shall be calculated in accordance with National Fire Protection Association Standard 1142. Please contact the Fire Marshal's Office for special help and other requirements that will apply. (SFC Appendix B, Sec. B103.3)

19) COMMERCIAL BUILDINGS - FIRE HYDRANTS: No portion of the exterior of a commercial building shall be located more than 400 feet from a fire hydrant when measured in an approved manner around the outside of the building and along an approved fire apparatus access roadway. Any hydrants that are left over from the minimum number of hydrant calculations may be fulfilled by hydrants that are up to 500 feet from any point of the building. (SFC Sec. 508.5.1)

Exception: Buildings equipped throughout with an approved automatic sprinkler system installed in accordance with NFPA 13 or 13R, the distance requirement shall be 600 feet.

20) COMMERCIAL BUILDINGS - MINIMUM NUMBER OF FIRE HYDRANTS: The minimum number of fire hydrants for a building shall be based on the required fire flow prior to giving credit for fire protection systems. (SFC Appendix C, Table C105.1)

21) SUB-DIVISIONS, SINGLE FAMILY DWELLINGS, DUPLEXES AND OUTBUILDINGS - FIRE HYDRANTS: Fire hydrants for single family dwellings, duplexes, sub-divisions and outbuildings classed as Type U occupancy by the IBC, shall be placed at each intersection. Intermediate fire hydrants are required if any portion of a structure exceeds 600 feet from a hydrant at an intersection as measured in an approved manner around the outside of the structure and along approved fire apparatus access roadways. Placement of additional fire hydrants shall be as approved by the Chief. (SFC Sec. 508.5.1)

22) Considerations for placing fire hydrants shall be as follows:

- Fire hydrant placement shall be approved by the fire district. All measurements are as the hose is laid by fire fighting personnel and apparatus.
- Existing hydrants in the area may be used to meet the required number of hydrants; however, hydrants that are over 500 feet away from the nearest point of the subject building shall not contribute to the required number of hydrants.
- Hydrants that are separated from the subject building by divided highway, freeway, or heavily traveled collector streets shall not contribute to the required number of hydrants.
- Hydrants that are accessible only by a bridge shall be acceptable to contribute to the required number of hydrants only if approved by the Chief.
- Private hydrants or public hydrants that are on adjacent private property shall not contribute to the required number of hydrants for the subject building.

Note: The use of hydrants located on other private property may be considered if their locations and access are encumbered in a legal document (such as an easement) by the owners of the involved parcels of property. The encumbrance may be lifted only after approvals by the Chief on behalf of the fire department and any other governmental agencies that may require approval. (SFC Sec. C104)

- Where fire hydrants are subject to impact by a motor vehicle, guard posts or other approved means of protection shall be provided. (SFC Sec. 508.5.6)
- When evaluating the placement of hydrants at apartment or industrial complexes the first hydrant(s) to be placed shall be at the main entrance and any secondary access to the site. After these hydrants have been placed other hydrants shall be sited to meet the above requirements for spacing and minimum number of hydrants.
- Fire hydrants shall be placed not more than 15 feet from an approved access roadway unless approved by the chief.

23) FIRE HYDRANT/FIRE DEPARTMENT CONNECTION CLEARANCE: A 3-foot clear space shall be maintained around the circumference except as otherwise required or approved. No parking within 10 feet and no closer than 4 feet from any supporting structure for electrical equipment such as transformers and poles. (SFC Sec. 508.5.5 and 912.3)

24) SINGLE FAMILY DWELLINGS, DUPLEXES - REQUIRED FIRE FLOW: The minimum fire-flow requirements for one- and two-family dwellings having a fire-flow calculation area which does not exceed 3,600 square feet shall be 1,000 gallons per minute. Fire flow and flow duration for dwellings having a fire-flow calculation area in excess of 3,600 square feet shall not be less than that specified in Appendix B, Table B105.1.

25) ACCESS AND FIRE FIGHTING WATER SUPPLY DURING CONSTRUCTION: Approved fire apparatus access roadways and fire fighting water supplies shall be installed, operational and made available by the time combustible material arrives on the site. (SFC Sec. 501.4, 1410.1 and 1412.1)

26) FIRE HYDRANT/FIRE DEPARTMENT CONNECTION: A fire hydrant shall be located within 150 feet of a fire department connection (FDC). Fire hydrants and FDC's shall be located on the same side of the fire apparatus access roadway. FDC locations shall be approved by the Chief. (SFC, Sec. 912.2)

27) FIRE DEPARTMENT CONNECTION FOR EACH BUILDING: Each building shall be provided with its own fire department connection unless approved by the fire code official. (SFC Sec. 912.1)

28) FIRE DEPARTMENT CONNECTIONS VISIBLE LOCATION: Fire department connections shall be located on the street side of buildings, fully visible and recognizable from the street or nearest point of fire department vehicle access or as otherwise approved by the fire code official. (SFC Sec. 912.2.1)

29) FIRE DEPARTMENT CONNECTION SIGNS: A metal sign with raised letters at least 1 inch in size shall be mounted on all FDC's serving fire sprinklers, standpipes or fire pump connections. Such signs shall read: "AUTOMATIC SPRINKLERS" or "STANDPIPES" or "TEST CONNECTION" or a combination thereof as applicable. (SFC Sec. 912.4)

- 30) FIRE DEPARTMENT CONNECTION BACKFLOW PREVENTION:** Potable water supplies to automatic sprinkler and standpipe systems shall be protected against backflow as required by the International Plumbing Code. (SFC Sec. 912.5)
- 31) WATER FLOW ALARMS:** Water flow alarm devices shall be provided on the exterior of the building. Water flow alarms shall be a listed device approved for exterior use in accordance with NFPA 13. Its location shall be in the vicinity of the fire sprinkler riser and visible from the FDC that supplies that system. (SFC Sec. 903.4.2)
- 32) KNOX BOX:** A Knox Box for building access is required for buildings with fire sprinkler systems, fire alarm systems, elevators or restricted access such as locked gates. Please contact the Fire Marshal's Office for an order form and instructions regarding installation and placement. Orders can be made directly from Knox Box at their website, www.knoxbox.com. Please reference Sedona zip code, 86336 for all orders. (SFC Sec. 506.1)
- 33) ADDRESSING:** New and existing buildings shall have approved address numbers, building numbers or approved building identification placed in a position that is plainly legible and visible from the street or road fronting the property. These numbers shall contrast with their background. Address numbers shall be Arabic numerals or alphabet letters. Numbers shall be a minimum of 4 inches (102 mm) high with a minimum stroke width of 0.5 inch. Flag lot addresses shall be posted on a minimum 4 x 4 post, not less than 4 feet tall, at the entrance to the driveway from the public street. If there is more than one dwelling, the one closest to the public street shall be first from front to back. (SFC 505.1)

SFC = 2012 Sedona Fire Code

IBC= International Building Code

Commercial Building = All occupancy classes as classed by the Building official other than Residential Group R-3 and Utility/Miscellaneous Group U.

Dwelling Unit = a single-family residential structure, or a single apartment unit.

Dead End, Turning Radius and No Parking Sign Diagrams

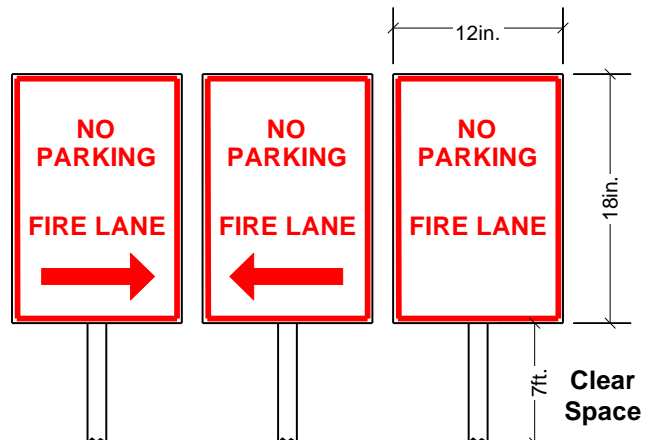
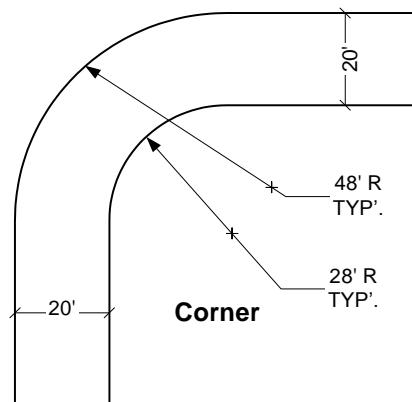
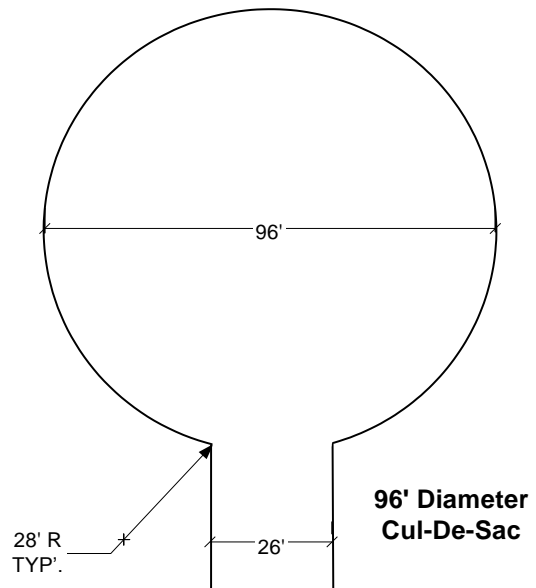
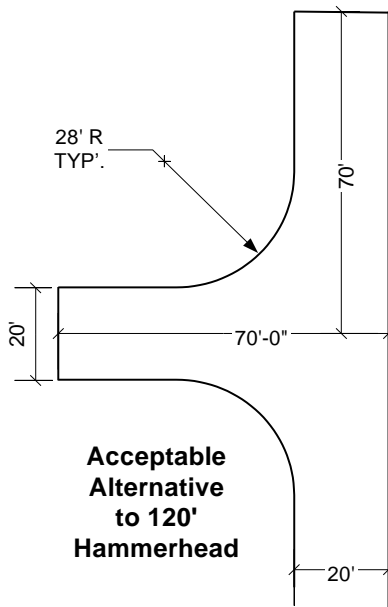
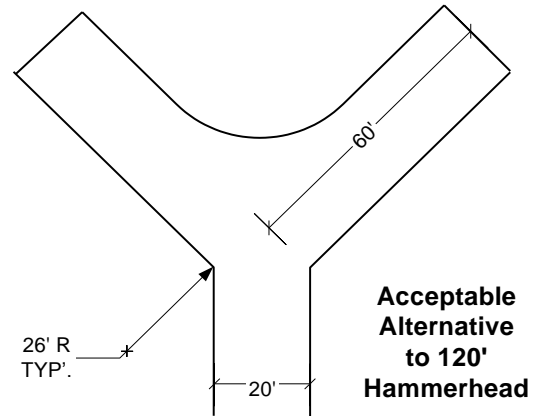
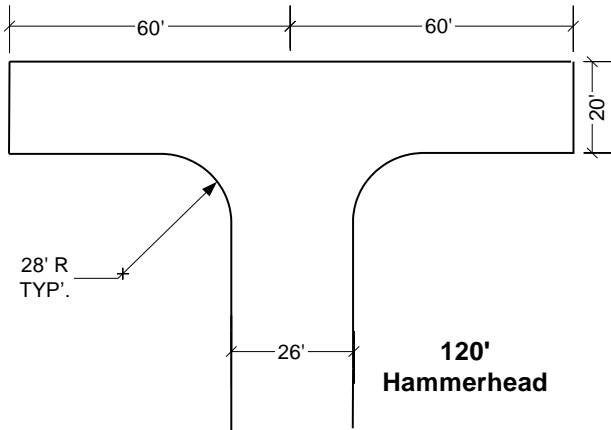

Fire Department Access Criteria

The following requirements have been adopted by Sedona Fire District as established minimum access roadway design criteria for fire apparatus to all proposed and newly constructed structures.

Wheel load

Required access roads and streets shall be constructed to support a minimum of 12,500 pounds wheel point load and a gross vehicle weight of 75,000 pounds. Road design and compaction reports verifying load carrying capacity shall be submitted prior to construction. An inspection may be required for final approval.

Wheel load is weight applied to contact area.

